

Coriolis Mass Flow Meter MULTICOR®-S



- **Continuous mass flow measurement according to the Coriolis principle**
- **Highly accurate measuring principle**
- **Quick measurement value acquisition, with excellent control capability**
- **Rugged design**
- **Cost effective and easily integration**
- **Dust-tight housing**

Application

Designed as an enclosed measuring system for the acquisition of flow rates and totalized amounts, the MULTICOR® Coriolis Mass Flow Meter is suited for throughput and consumption measurement:

- throughput and consumption measurement
- totalizing
- batching

of materials with good to slightly sluggish flow properties.

Equipped with controllable prefeeder (e.g. star feeder, flow gate or screw), the measuring system can also be used as feed system.

The MULTICOR® series offers solutions for many applications:

- MULTICOR®-S
Gravity feed into processes

Equipment

A MULTICOR®-S Coriolis Mass Flow Meter consists of:

- dust-tight stainless steel housing
- measuring wheel with guide vanes
- weighing module
- cable junction box
- AC three-phase geared motor.

All contact parts are of stainless steel.

The inlet connection for attachment to user's infeed line is equipped with DIN flange or Jacob's pipe connection.

The outlet cone is equipped with a flexible sleeve for connection to user's feed line.

The weighing module arranged outside of material casing thus enabling the system to be used even at material temperatures of up to 130° Celsius.

Functions

The MULTICOR® Mass Flow Meter use the Coriolis force measurement principle to determine the mass flow. Within the device, the material flow to be measured hits a measuring wheel, rotation at constant speed.

The material is accelerated to the measuring wheel circumferential speed by the guide vanes.

This acceleration produces a torque directly corresponding to the flow rate. The torque is measured by a measuring module and converted into an electrical signal.

The measurement is independent of mechanical material properties, e.g. grain size, flow behaviour, moisture and temperature.

The material friction on the measuring wheel and flow speed variations in the measuring system do not affect the measuring signal.

Dimensions [mm]

Coriolis Mass Flow Meter MULTICOR®-S40

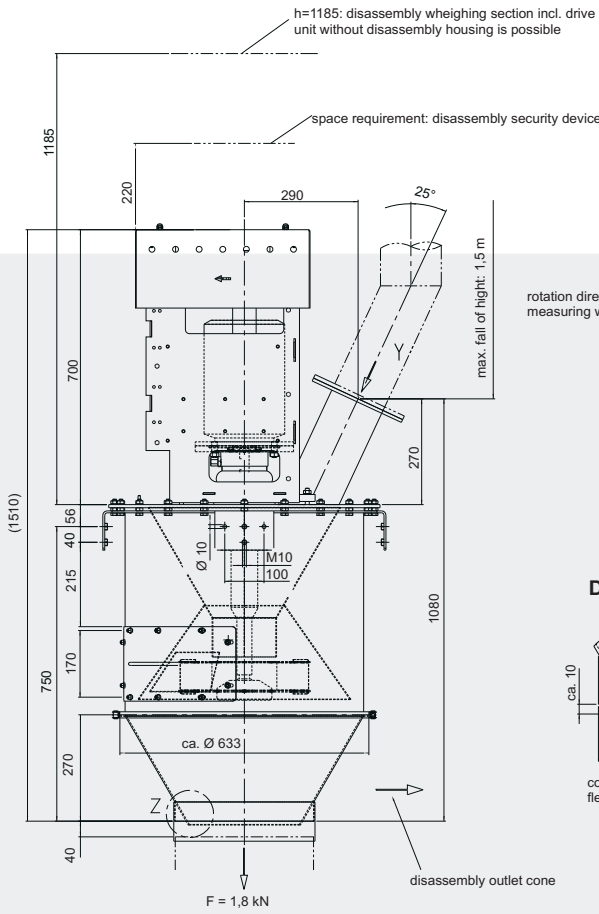

Top View

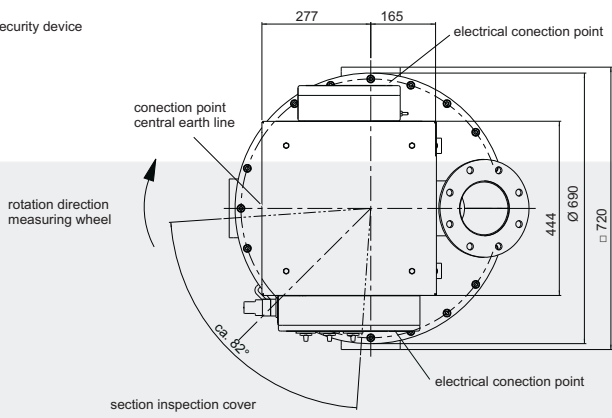

Detail "Z"

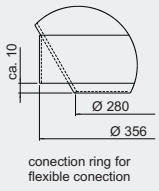

View "Y"

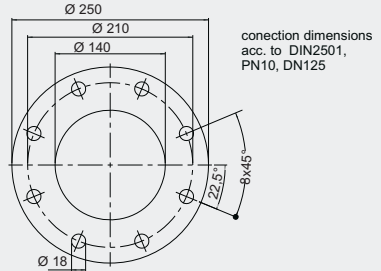

Coriolis Mass Flow Meter MULTICOR®-S80

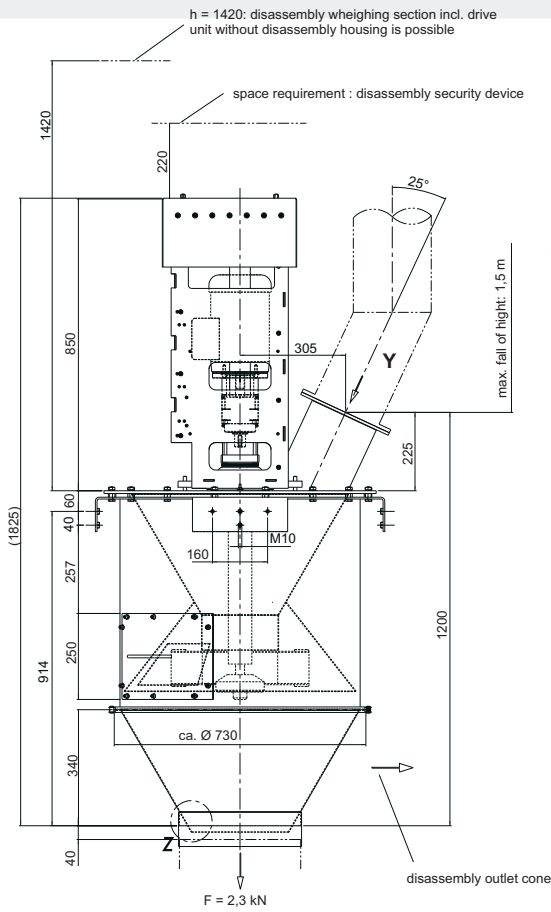

Top View

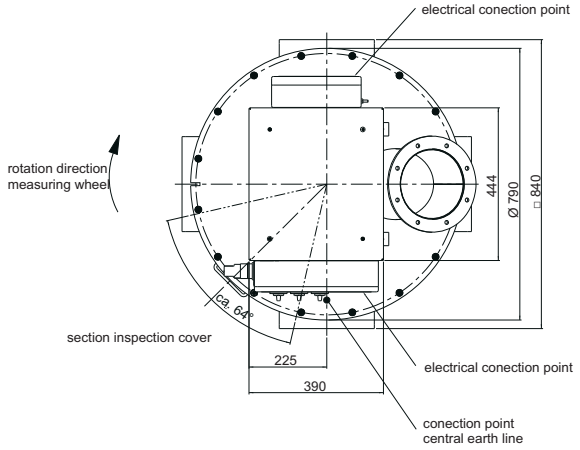

Detail "Z"

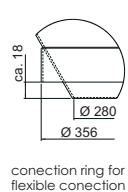

View "Y"

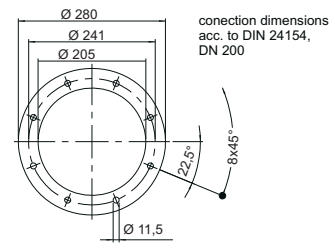

Coriolis Mass Flow Meter MULTICOR®-S160

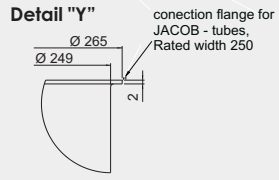
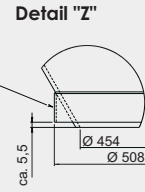
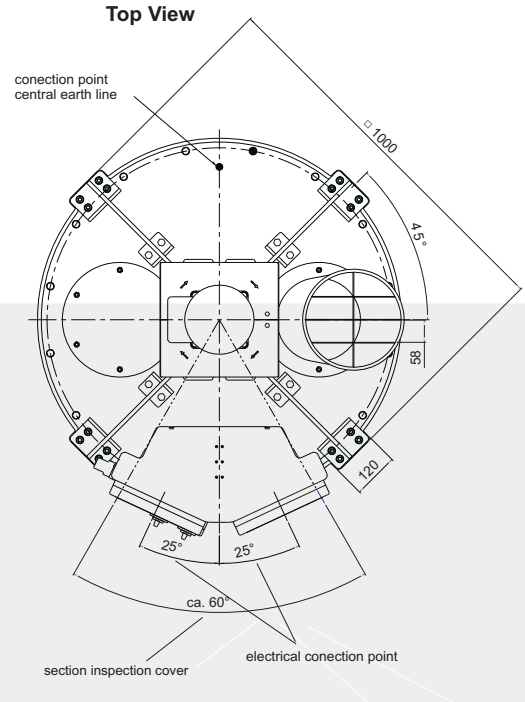
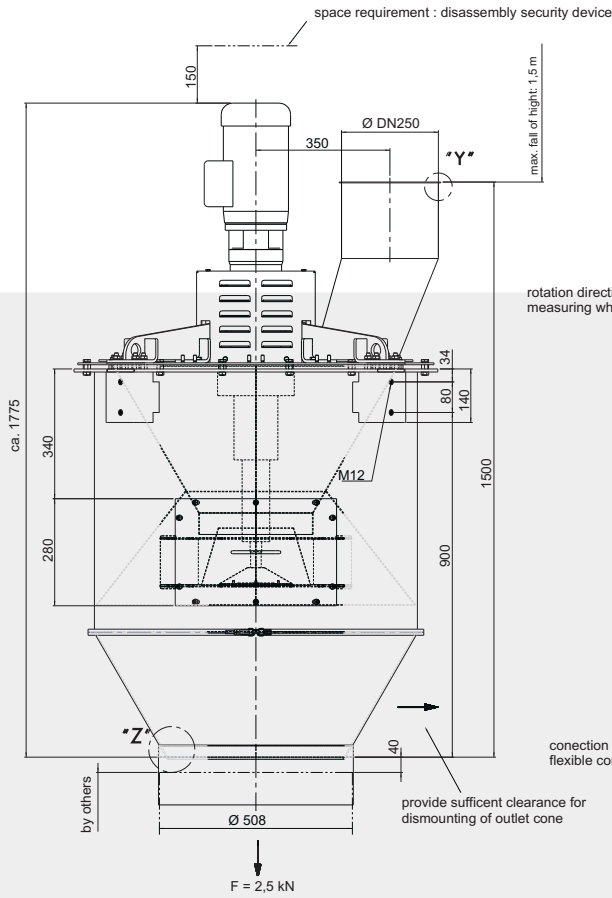

Coriolis Mass Flow Meter MULTICOR®-S260

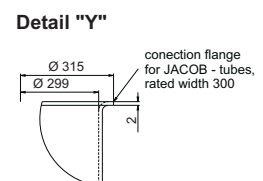
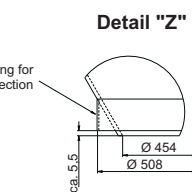
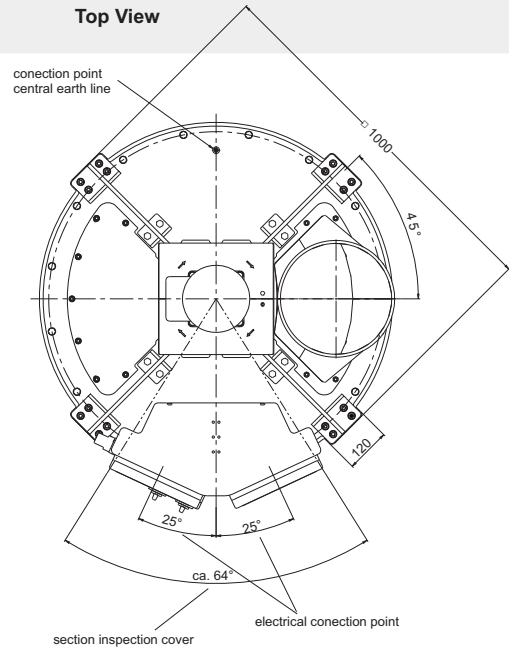
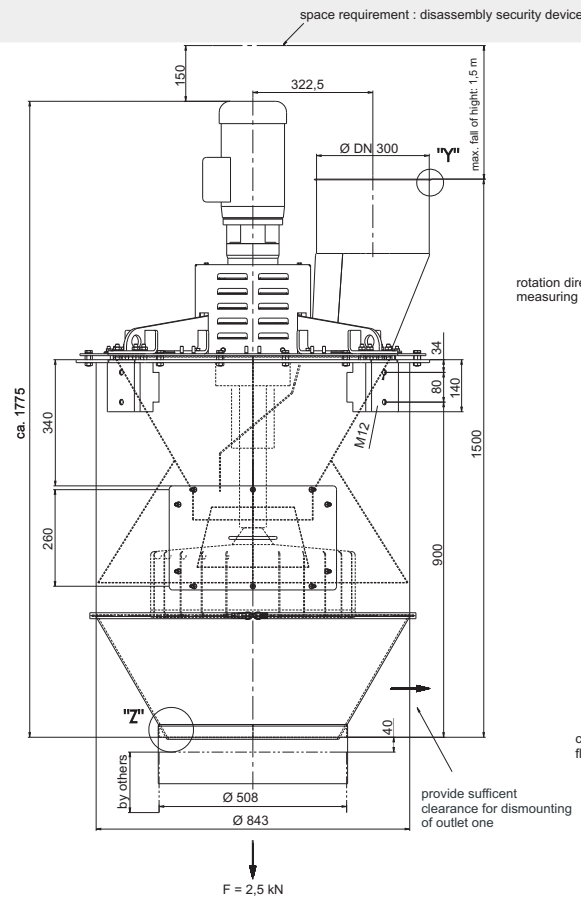

Coriolis Mass Flow Metere MULTICOR®

Series	S40	S80	S160
Flow rate	min. 0,5 t/h–max. 20 t/h (40 m³/h)	min. 2 t/h–max. 60 t/h (80 m³/h)	min. 6 t/h–max. 150 t/h (160 m³/h)
Accuracy (rated to actual flow rate)	from 0.5 % (depending on system configuration)		
Setting range	1 : 10		
Operating pressure	- 10 mbar to +30 mbar		
Pressure variations	± 5 mbar		
Inlet size	Ø 140 mm (DIN 2501 DN 125)	Ø 200 mm (DIN 24154)	Ø 249 mm (AnschlussbördeJ JAKOB-Rohr, Nennweite 250)
Outlet connecting dimensions	Ø 356 mm		Ø 508 mm
Weight	180 kg	230 kg	250 kg
Ambient temperature	-25° bis +40° C (+50°C)		
Material temperature	max. 130° C		
Material density	min. density 0,3 t/m³		
Grain size	max. 5 mm (single grain up to max. Ø 30 mm)		max. 8 mm (single grain up to max. Ø 30 mm)
Moisture	max. 1%		
Flow properties	free flowing to slightly sluggish, also flushing, non-sticky, pulverized to granular		
Contact parts	housing, measuring wheel WS 1.4404 / AISI 316 LN		
Special type for PE/PP Powder Feeds			
Series	S80	S160	S260
Flow rate	min. 2 t/h–max. 60 t/h (70 m³/h)	min. 6 t/h–max. 150 t/h (160 m³/h)	min. 4 t/h–max. 100 t/h (260 m³/h)
Grain size	max. 5 mm (single grain up to max. Ø 45 mm)	max. 8 mm (single grain up to max. Ø 50 mm)	
Contact parts	housing, measuring wheel WS 1.4404 / AISI 316 LN Option: measuring wheel Polyurethan		

Accuracy

The stated accuracy relates to the actual flow rate in the 10 – 100% range provided that

- System is installed and calibrated in accordance with our installation and calibration instructions.

Thanks to the Coriolis measuring principle, accuracy is not affected by varying material properties (flow behaviour, moisture, temperature, grain size).

Additional Requirements

Should you have any special requirements, e.g.:

- bigger flow rate range
- use in the hazardous area
- direct infeed into pneumatic feed lines
- use as feed system, please let us know.

Ordering Data

For us to be able to process your order smoothly and quickly, please let us have the following data in addition to ordering numbers:

Material Data

Bulk density[t/m³]
Material

Promotion Strength Range

from[t/h]
to[t/h]

Variants

MULTICOR®-S40 Coriolis Mass Flow Meter for 0,5 t/h – 20 t/h with 50 Hz-Drive, 0,5 t/h – 18 t/h with 60 Hz-Drive
MULTICOR®-S80 Coriolis Mass Flow Meter for 2 t/h – 60 t/h with 50 / 60 Hz-Drive
MULTICOR®-S160 Coriolis Mass Flow Meter for 6 t/h – 150 t/h with 50 / 60 Hz-Drive
MULTICOR®-S260 Coriolis Mass Flow Meter for 4 t/h – 100 t/h with 50 / 60 Hz-Drive

Options

Wear lining for MULTICOR®-S
Prefeeder for MULTICOR®-S
Noise protection
Measuring rotor with non-adhesive coating
Measuring wheel in special type for PE/PP powder feeds

Schenck Process GmbH

Pallaswiesenstr. 100
64293 Darmstadt, Germany
T +49 6151 32-1216
F +49 6151 32-1172
sales@schcnckprocess.com
www.schenckprocess.com